

TECHNICAL DATA SHEET BUMP RAIL

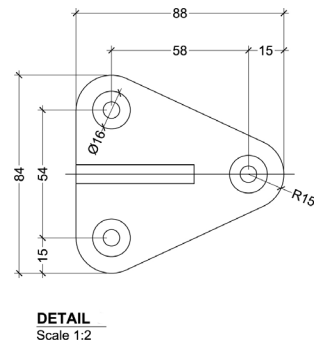

An ideal solution for protecting your assets from shopping carts, pallet jacks, motorised floor scrubbers and more, A1C's bump rail can be custom designed and fitted to suit any requirement.

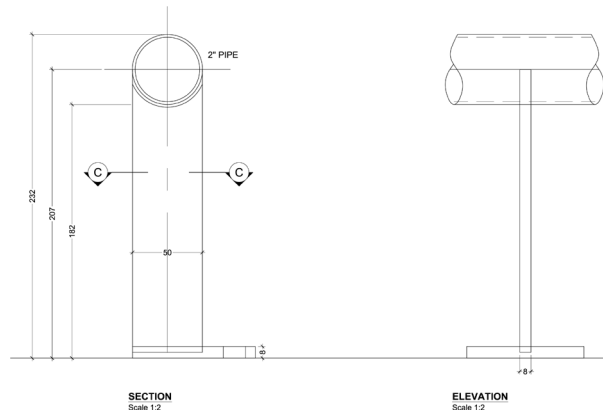

FEATURES

- Heavy Duty
- High Quality
- Custom Fitted
- Cut to Length

	HEIGHT	LENGTH	DIAMETER	THICKNESS	MATERIAL	FIXING	FINISH
PEDESTAL							
	200 mm & Custom	-	-	10 mm & Custom	SS304 SS316 SS316L Mild Steel	Screw Adhesive	SS Brushed SS Polished Galvanised Painted Powder Coated
RAIL							
	-	6LM Lengths & Cut to Length	2", 2.5" 3", 3.5" 4", 7" Custom	1.2 mm & Custom	SS304 SS316 SS316L Mild Steel	-	SS Brushed SS Polished Galvanised Painted Powder Coated

ACCESS 1 CONTROLS - UAE

European Business Centre PO Box 473549
Dubai Investment Park 1, Dubai UAE
T: +971 (0) 4 813 5212 | F: +971 (0) 4 813 5213
E: sales@access1c.com | W: www.access1c.com

ACCESS 1 COMPANY - AUSTRALIA

7 Lucknow Crescent
Thomastown Victoria, Australia
T: +61 (03) 9469 3600 | F: +61 (03) 9469 3622
E: sales@accessone.com.au | W: www.accessone.com.au